

YCAL-SB Millennium™



AIR COOLED LIQUID CHILLER

R407C REFRIGERANT

**COOLING CAPACITIES
141 kW to 360 kW**

YORK YCAL-SB Millennium™ air cooled scroll liquid chillers provide chilled liquid for all air conditioning applications. They are completely self-contained and are designed to be located outside on the roof of a building or at ground level.

Each unit includes four, five or six hermetic scroll compressors, a liquid cooler, air cooled condensers, and a weather resistant microprocessor control centre, all mounted on a formed steel base.

CONTENTS

Specification

Accessories and Options

Controls

Operating Limitations

Refrigeration Flow Diagram

Selection Guide

Water Pressure Drops

Cooling Capacities

Physical Data

Electrical Data

Electrical Connections

Space Requirements

Dimensions



AVAILABLE MODELS & NOMINAL COOLING CAPACITIES TABLE 1

Model	0147SB	0173SB	0197SB	0217SB	0253SB
Cooling Capacity (kW)	141	162	186	208	238

Model	0287SB	0317SB	0347SB	0377SB
Cooling Capacity (kW)	277	306	340	360

Cooling capacities at 7 °C leaving chilled liquid and 35 °C ambient.

FEATURES	BENEFITS
High efficiency.	Low operating costs.
Electronic Expansion Valves (EEV) fitted as standard.	Enhanced efficiency and improved part load performance.
Manufactured to ISO 9001/EN 29001.	High standard of quality control.
Full factory run test.	Verifies quality control and ensures that the unit operates satisfactorily prior to delivery.
Optional acoustic kits.	Reduced sound levels for low sound applications.
Small footprint.	High capacity design ideal for reduced base area applications.
Two refrigerant circuits.	System stand-by security.
Accessible components.	Ideal for maintenance operations
Microprocessor control with visual display of temperatures and alarms.	Simple operation.
Optional multi-unit sequencer.	Sequencing up to eight chillers in parallel based on mixed leaving liquid temperature.
Chiller remote alarm contacts.	Remote alarm notification.
Single power and control supply.	Easy to install and minimises site wiring costs.
Optional remote liquid temperature reset.	Improved operating efficiency at part load and reduced operating costs.

SPECIFICATION

The chillers shall be completely factory assembled with all interconnecting refrigerant piping and wiring ready for field installation. After assembly the unit shall have a full test run with water flowing through the cooler. The unit shall be pressure tested, evacuated and fully charged with refrigerant and include an initial oil charge.

The unit structure is heavy-gauge, galvanised steel coated with baked-on powder paint (Desert Sand (RAL 1019)).

Compressors

The unit shall have hermetic scroll compressors. High efficiency is achieved through a controlled orbit and the use of an advanced scroll geometry. All rotating parts are statically and dynamically balanced. The compressor motors shall have integral protection against overloads. The overload protection will automatically reset. Starting shall be direct on line. The motor terminal boxes shall have IP-54 weather protection.

The compressors shall be switched On and Off by the unit microprocessor to provide capacity control. Each compressor is fitted with a crankcase strap heater.

Cooler

The cooler is equipped with a heater controlled by a separate thermostat. The heater provides freeze protection for the cooler down to -29°C ambient. The cooler is covered with 19 mm flexible, closed-cell, foam insulation.

The removable head allows access to the internally enhanced, seamless, copper tubes. Flanged water connections and vent and drain connections are included.

Refrigerant Circuits

Each circuit will use copper refrigerant pipe formed on computer controlled bending machines to reduce the number of brazed joints resulting in a reliable and leak resistant system.

Liquid line components shall include: a service valve with charging port, a high absorption removable core filter-drier, a sight glass with moisture indicator and service valve. In addition, a combined electronic expansion valve / solenoid valve and suction temperature sensor in each refrigerant circuit, provides improved part load performance. The control panel is fitted with all the electrical components to operate the valves.

Suction line components shall include: a pressure relief valve, a service valve and a pressure transducer. Suction lines shall be covered with closed-cell insulation. An optional ball valve is available for circuit isolation.

Models YCAL0147 to 0253

Discharge lines shall include: a service valve, two high pressure cutout switches, a pressure transducer and a check valve. An optional ball valve (and pressure relief valve) is available to replace the check valve for circuit isolation.

Models YCAL0287 to 0377

Discharge lines shall include: a service valve, two high pressure cutout switches and a pressure transducer. An optional ball valve (and pressure relief valve) is available for circuit isolation.

Air Cooled Condensers

The condenser coils shall be seamless copper tubes, arranged in staggered rows, mechanically expanded into corrugated aluminium fins. Integral sub-cooling will be included. Design working pressure of the coils shall be 27.9 barg (405 psig).

The condenser fans shall be composed of corrosion resistant aluminum hub and glass fibre reinforced polypropylene composite blades moulded into a low noise aerofoil section. They are designed for maximum efficiency and statically and dynamically balanced for vibration free operation. They shall be directly driven by independent motors, and positioned for vertical air discharge. The fan guards will be constructed of heavy-gauge, corrosion resistant, coated steel.

The fan motors shall be totally enclosed air-over (TEAO), squirrel-cage type. They will feature ball bearings that are double-sealed and permanently lubricated.

Power and Control Panels

All power and controls will be contained in a IP55 cabinet with hinged and lockable outer doors. Power and control sections will be housed in separate enclosures.

The power panel shall include:

- A factory mounted non-fused disconnect switch with external, lockable handle to enable connection of the unit power supply. The disconnect switch can be used to isolate the power for servicing.
- Factory mounted compressor manual motor starters (to provide overload and short circuit protection).
- Compressor motor starting contactors.
- Factory mounted control transformer to convert the unit supply voltage to 115 V - 1 Ø - 50 Hz for the control system.
- Fan contactors with overload current protection.
- Customer terminal block for status outputs and chilled liquid pump.

All exposed power wiring will be routed through IP66 non-metallic conduit.

FIGURE 1

CONTROL PANEL

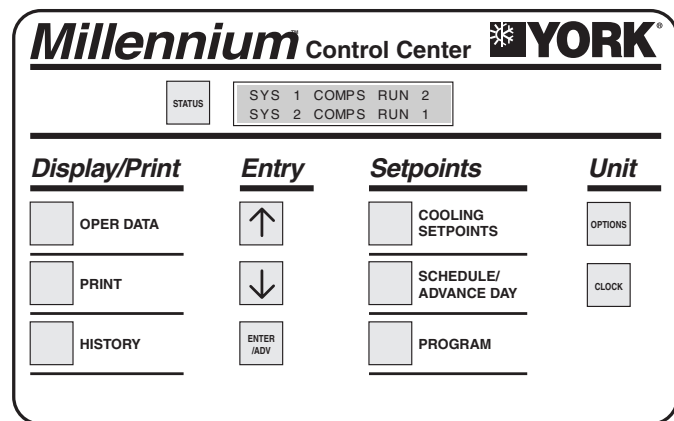

The control panel shall include:

- A Liquid Crystal Display (two display lines of twenty characters per line) with Light Emitting Diode back lighting for outdoor viewing.
- A Colour coded 12-button keypad.
- Customer terminal block for control inputs and liquid flow switch.

The microprocessor control will include:

Status Key for display of:

- Status of the unit and each refrigerant circuit
- System and unit safety fault messages

Display/Print Keys for display of:

- Chilled liquid and ambient air temperatures
- System pressures (each circuit)
- Operating hours and starts (each compressor)
- Load and unload timers and cooling demand
- Liquid pump, evaporator heater, solenoid valve and condenser fan status

Print calls up to the liquid crystal display:

- Operating data for the systems
- History including time, date and reason for last fault shutdown

An RS-232 port, in conjunction with this press-to-print button, is provided to permit the capability of hard copy print-outs via a separate printer (by others).

Entry Keys

- To program and modify system values

Setpoints Keys for programming:

- Chilled liquid temperature setpoint and range
- Remote reset temperature range
- Set daily schedule/holiday for start/stop
- Manual override for servicing
- Low and high ambient cutouts
- Low liquid temperature cutout
- Low suction pressure cutout
- High discharge pressure cutout
- Anti-recycle timer (compressor start cycle time)

Unit Keys

- To set time and unit options

Unit **ON/OFF** switch

- To activate or deactivate the unit

The microprocessor control system is capable of displaying the following:

- Return and leaving liquid temperature
- Low leaving liquid temperature cutout setting
- Low ambient temperature cutout setting
- Ambient air temperature
- Metric or Imperial data
- Discharge and suction pressure cutout settings
- System discharge and suction pressures
- Anti-recycle timer status
- Anti-coincident system start timer condition
- Compressor run status
- No cooling load condition
- Day, date and time
- Daily start/stop times
- Holiday status
- Automatic or manual system lead/lag control
- Lead system definition

- Compressor starts & operating hours (each compressor)
- Status of evaporator heater and fan operation
- Run permissive status
- Number of compressors running
- Liquid solenoid valve status
- Load & unload timer status
- Water pump status
- Liquid Temperature Reset via a YORK ISN DDC or Building Automation System (by others)

Provisions shall be included for: pumpdown at shutdown; optional remote chilled water temperature reset or up to two steps of demand load limiting (depending on model) from an external building automation system.

The operating program will be stored in non-volatile memory (EPROM) to eliminate chiller failure due to AC power failure/battery discharge. Programmed setpoints shall be retained in lithium battery backed RTC memory.

ACCESSORIES AND OPTIONS

POWER OPTIONS:

Power Factor Correction - Factory mounted passive (static) power factor correction capacitors to correct unit compressor power factors to a target of 0.9 - 0.95 (depending on operating conditions).

Softstart (Models 0147 to 0253 only) - Factory fitted and wired reduced current softstart on compressor No. 2. of each circuit on models 0147 and 0173 or compressor No. 3 of each circuit on models 0197, 0217 and 0253.

Softstart and Power Factor Correction Combination (Models 0147 to 0253 only) - Softstart is factory fitted on compressor no.2 of each circuit of models 0147 and 0173, or compressor no. 3 on each circuit of models 0197, 0217 and 0253. Power factor correction is fitted to remaining compressors without softstart fitted. Power factor correction cannot be fitted to a compressor with softstart fitted.

CONTROL OPTIONS:

Low Ambient Kit (Models 0147 to 0253 only) - Standard units will operate to -4°C. This accessory includes all necessary components to permit chiller operation to -18°C.

Note: Models 0287 to 0377 will operate to -18°C ambient as standard.

Building Automation System (BAS) Interface - The addition of a factory mounted PCB to accept a 4-20 mA, 0-10 Vdc or contact closure input to reset the leaving chiller liquid temperature from a building automation system. (Cannot be fitted when a Remote Control Panel or Multi-unit Sequence Control is fitted).

Note:

- The standard unit capabilities include remote start-stop, remote water temperature reset via a PWM input signal or up to two steps of demand (load) limiting depending on model.
- The standard unit control panel can be directly connected to a YORK Building Automated System via the standard on board RS485 communication port.

Language LCD and Keypad - Spanish, French, German, and Italian unit LCD read-out and keypad available. Standard language is English.

Remote Control Panel and Wall Adaptor - Field mounted remote control panel (Cannot be fitted when a (BAS) Interface or Multi-unit Sequence Control is fitted).

Multi-unit Sequencing - A field mounted Sequencing Control Centre to manage sequencing control of up to eight chillers in parallel based on mixed liquid temperature (interconnecting wiring by others). (Cannot be fitted when a (BAS) Interface or Remote Control Panel is fitted).

REFRIGERANT CIRCUIT OPTIONS:

Low Temperature Glycol (Brine) - Vessel design to allow operation with leaving glycol temperatures between -1°C and -6°C (Models 0147 to 0253) and between -1°C and -10°C (Models 0287 to 0377).

Isolation Valves - One set of ball valves per refrigerant circuit for isolation. Factory installed valve and pressure relief valve in the high pressure (discharge) and valve in the low pressure (suction) pipework.

Mechanical Gauge Kit - Factory fitted mechanical pressure gauges for display of suction and discharge pressures, one complete set per system.

DX COOLER OPTIONS:

38 mm Insulation - Double thickness insulation provided for enhanced efficiency, and low temperature applications.

10.5 bar (150 PSI) DWP Flow Switch - Vapour-proof SPDT switch, -29°C to 121°C, with 1" NPT connection for upright mounting in horizontal pipe (field mounted).

CONDENSER OPTIONS:

Copper Fin Condenser Coils - Condenser coils are constructed with copper fins (ASTM 287 Test, after 1500 hours 17% weight loss).

Gold Epoxy Coated Aluminium Condenser Fins - Offers corrosion resistance in mild seashore locations (ASTM 287 Test, after 1500 hours 7% weight loss).

Blygold Protective Coating - is recommended for corrosive applications, such as coastal locations where salt spray may hit the condenser fins (ASTM 287 Test, after 1500 hours 0% weight loss).

High Static Pressure Fans - Fans and motors suitable for high external static conditions.

SOUND OPTIONS:

Compressor Acoustic Sound Blanket - Each compressor is individually enclosed by an acoustic sound blanket:

Models 0147 to 0253 - The sound blankets are made with one layer of acoustical absorbent textile fibre of 15 mm thickness and one layer of anti-vibrating heavy material thickness of 3mm. Both are enclosed by two sheets of welded PVC, reinforced for temperature and UV resistance (factory mounted).

Models 0287 to 0377 - The sound blankets are made from a composite of materials giving a total jacket thickness of 15mm with an outer covering of PVC (factory mounted).

Low Sound Fans - Reduced RPM fan motors and alternative fan selection for low sound applications (factory mounted).

Dual Speed Fans - Dual speed fans offer a very low sound alternative. Fan operates either in high mode (660rpm) or in low mode (520rpm). Fan speed reduces from high to low mode as head pressure falls, typically when the ambient is less than 25-28°C depending on model size.

UNIT ENCLOSURES:

Wire Enclosure - Welded wire mesh guards mounted on the exterior of the unit (factory mounted).

Louvered Panels and Wired Guards (Models 0147 to 0253 only) - Louvered panels mounted over the exterior condenser coil faces, and welded wire mesh guards mounted around the bottom of the unit (factory mounted).

Louvered Panels [condenser coils only] (Models 0147 to 0253 only) - Louvered panels are mounted over the exterior condenser coil faces on the sides of the unit to visually screen and protect the coils (factory mounted).

Louvered Panels [full unit] (Models 0147 to 0253 only) - Louvered panels over condenser coils and around the bottom of the unit (factory mounted).

VIBRATION ISOLATION:

Neoprene Pad Isolators - Recommended for normal installations (field mounted).

25 mm Spring Isolators - Level adjustable, spring and cage type isolators for mounting under the unit base rails (field mounted).

50 mm Seismic Spring Isolators - Restrained Spring-Flex Mountings incorporate welded steel housing with vertical and horizontal limit stops. Housings designed to withstand a minimum 1.0 g accelerated force in all directions to 50 mm. Level adjustable, deflection may vary slightly by application (field mounted).

TABLE 2 OPERATING LIMITATIONS

Model				0147SB		0173SB		0197SB		0217SB		0253SB		
				Min.	Max.	Min.	Max.	Min.	Max.	Min.	Max.	Min.	Max.	
Chilled Liquid	Liquid outlet temperature	Water outlet	°C	5.5°C To 13°C										
			Glycol outlet	°C	-6.7°C To 13°C									
		Temp. spread		°C	3.3°C To 8°C									
	Flow rate			l/s	5.5	15.8	5.5	15.8	7.3	27.7	7.3	27.7	8.6	27.8
	Pressure drop			kPa	13.1	33.5	13.1	33.5	10.5	47.1	10.5	47.1	12.6	48.6
Max. working pressure			barg	10.35										
Ambient Air	Air Entering temperature	Standard units	°C	-4°C To 46°C										
		Low ambient units	°C	-18°C To 46°C										
	Fan available static pressure	Standard fans	Pa	20										
		Low sound fans	Pa	10										
		Dual speed fans	Pa	0 (520 rpm)				10 (660 rpm)						
Power supply voltage 400 V, 3 Ø, 50 Hz (nominal)			V	360 To 440										
Recommended system volume ⁽¹⁾			l	568		680		755		832		1004		

Model				0287SB		0317SB		0347SB		0377SB	
				Min.	Max.	Min.	Max.	Min.	Max.	Min.	Max.
Chilled Liquid	Liquid outlet temperature (water)		°C	5.5°C To 13°C							
	Liquid outlet temperature spread		°C	3.3°C To 8°C							
	Flow rate		l/s	10.0	28.0	10.0	28.0	11.0	35.0	11.0	35.0
	Pressure drop		kPa	16.0	59.5	16.0	59.5	16.8	65.0	16.8	65.0
	Max. working pressure			barg	10.35						
Ambient Air	Air Entering temperature (standard)		°C	-18°C To 45°C							
	Fan available static pressure	Standard fans	Pa	20							
		Low sound fans	Pa	10							
		Dual speed fans	Pa	0 (520 rpm)				10 (660 rpm)			
Power supply voltage 400 V, 3 Ø, 50 Hz (nominal)			V	360 To 440							
Recommended system volume ⁽¹⁾			l	1156		1310		1428		1563	

(1) Table shows minimum water / glycol volume of system

SELECTION GUIDE - WATER

DATA REQUIRED

To select a YORK YCAL-SB water chiller, the following information is required:

1. Required cooling capacity.
2. Design chilled liquid entering and leaving temperatures.
3. Design water flow rate if one of the temperatures in item 2 are unknown.
4. Design condenser entering air temperature. This will normally be the design summer ambient air temperature unless location or other factors have an influence.
5. Altitude above sea level.
6. Design Cooler fouling factor.
7. Static pressure resistance against condenser entering and leaving air flow (where ducts, louvres, attenuators, etc., are used) at full unit air volume.

Note: Items 1, 2 and 3 must be linked by the following formulae:

$$\text{Cooling capacity kW} = \frac{\text{l/s chilled liquid} \times \text{°C range}}{0.2392}$$

Where:

Range = Entering liquid temperature - Leaving liquid temperature.

CHILLER SELECTION METHOD

1. Determine the correct size of chiller by selecting the model which most closely matches the required capacity at the design conditions of leaving water temperature and entering air temperature (Table 10).
2. Apply the relevant correction factors for fouling factor, altitude and fan application (Tables 3 to 5) to the capacity and power values from the capacity table (Table 10). Ensure the corrected capacity is still sufficient for requirements.
3. Using the corrected capacity of the selected chiller adjust the design temperature range, or flow rate, to balance the formulae shown in "Data Required".

4. Physical and electrical data can now be determined from Tables 11 and 12.

5. Always re-check that selections fall within the design limitations specified (Table 2).

YCAL SAMPLE SELECTION - WATER COOLING

A R407C chiller is required to cool water from 12°C to 7°C having a cooling capacity of 160 kW.

Other design conditions applying are:

Ambient air entering condenser: 35°C
 Fouling factor: 0.044 m² °C/kW
 Altitude: Sea level

From a cursory examination of capacity table 10 a YCAL0173SB gives approximately the required capacity of 162.2 kW

Since no correction factors for fouling or altitude apply, the conditions will be as follows:

Cooling capacity: 162.2 kW
 Compressor power: 56.7 kW
 Water temperature: 12 °C to 7 °C
 Water flow rate $\frac{162.2 \times 0.2392}{5} = 7.76 \text{ l/s}$

Cooler pressure drop = 17.8 kPa (see Figure 3).

FIGURE 3 YCAL-SB COOLER PRESSURE DROPS

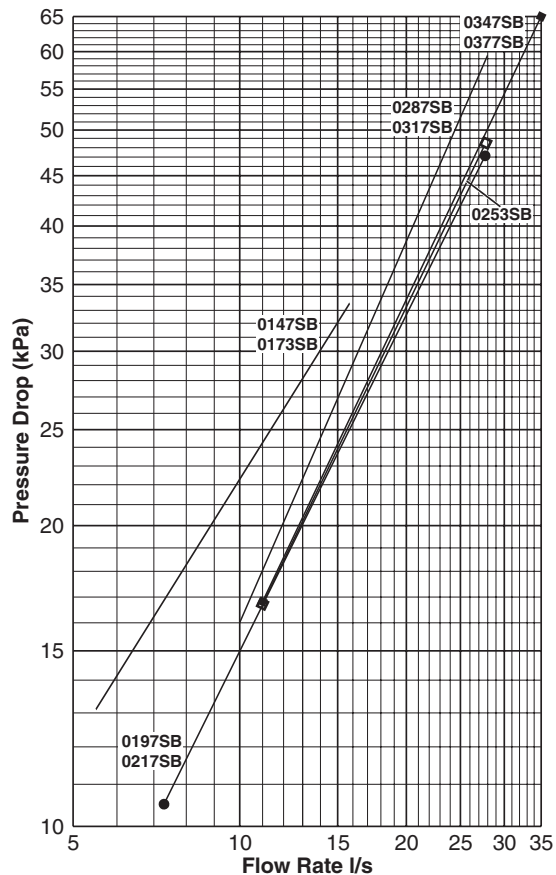

TABLE 3 FOULING FACTORS

COOLER		
Fouling Factor m ² °C/kW	Capacity Factor	Power Factor
0.044	1.000	1.000
0.088	0.987	0.995
0.176	0.964	0.985
0.352	0.995	0.962

TABLE 4 ALTITUDE FACTORS

Altitude (m)	Capacity Factor	Power Factor
0	1.000	1.000
600	0.987	1.010
1200	0.973	1.020
1800	0.958	1.029
2400	0.943	1.038

TABLE 5 FAN APPLICATION FACTORS

Fan Type	External Static (Pa)	Capacity Factor	Power Factor
Standard	0	1.000	1.00
	20	0.990	1.01
Low Sound (0147 to 0253)	0	0.985	1.02
	10	0.975	1.03
Low Sound (0287 to 0377)	0	0.980	1.01
	10	0.970	1.02
Dual Speed (520 rpm)	0	0.950	1.065
Dual Speed (660 rpm)	0	0.980	1.01
Dual Speed (660 rpm)	10	0.970	1.02

A capacity factor of 1.01 and a power factor of 0.992 should be applied when optional copper fin condenser coils are specified.

Model	Pressure Drop Calculation
0147SB 0173SB	Pressure Drop [kPa] = 2.8742 x (Flow Rate [l/s] ^{0.8898})
0197SB 0217SB	Pressure Drop [kPa] = 1.1208 x (Flow Rate [l/s] ^{1.1255})
0253SB	Pressure Drop [kPa] = 1.0597 x (Flow Rate [l/s] ^{1.1506})
0287SB 0317SB	Pressure Drop [kPa] = 0.8482 x (Flow Rate [l/s] ^{1.2756})
0347SB 0377SB	Pressure Drop [kPa] = 1.0185 x (Flow Rate [l/s] ^{1.1690})

SELECTION GUIDE - GLYCOL (MODELS 0147 TO 0253 ONLY)

DATA REQUIRED

To select a YORK YCAL-SB glycol chiller, the following information is required:

1. Required cooling capacity.
2. Design chilled liquid entering and leaving temperatures.
3. Design glycol flow rate if one of the temperatures in item 2 are unknown.
4. Design condenser entering air temperature. This will normally be the design summer ambient air temperature unless location or other factors have an influence.
5. Altitude above sea level.
6. Design cooler fouling factor.
7. Static pressure resistance against condenser entering and leaving airflow where ducts, louvres, attenuators, etc., are used, at full unit air flow.

Note: Items 1, 2 and 3 must be linked by the following formulae:

$$\text{Cooling capacity kW} = \frac{\text{l/s chilled liquid} \times \text{°C range}}{\text{Glycol Factor}}$$

Where:

Range = Entering liquid temperature - leaving liquid temperature.

The glycol factor is obtained from table 6 using the design leaving liquid temperature and the percentage by weight glycol concentration. **Recommended glycol concentrations for the unit are given in table 7.**

SELECTION METHOD

1. Determine the correct size of chiller by selecting the model which most closely matches the required capacity at the design conditions of leaving glycol temperature and entering air temperature.
2. Apply the relevant correction factors for fouling factor, altitude and fan application (Tables 3 to 5) and glycol concentration (Table 8), to the capacity and power values from the capacity table (Table 10). Ensure the corrected capacity is still sufficient for requirements.
3. Using the corrected capacity of the selected chiller, adjust the design temperature range, or flow rate, to balance the formulae shown in "Data Required".
4. Physical and electrical data can now be determined from Tables 11 and 12.
5. Always re-check that selections fall within the design limitations specified (Table 2).

YCAL-SB SAMPLE SELECTION - GLYCOL COOLING

A R407C chiller is required to cool propylene glycol from 2°C to -2°C having a cooling capacity of 160 kW.

Other design conditions applying are:

Ambient air entering condenser:	30°C
Fouling factor:	0.088m °C/kW
Altitude:	1200m
Glycol Strength:	29% w/w

For a - 2°C propylene glycol leaving temperature the recommended concentration from table 7 is 29%.

From the capacity table 10 an "Ethylene Glycol" temperature of "-3°C" leaving chilled liquid temperature (Propylene Glycol capacity = Ethylene Glycol capacity at 1°C lower temperature) at 30°C condenser entering air temperature a YCAL0217SB gives approximately the required capacity of 164.9 kW.

From the design fouling factor, corrections of capacity x 0.987 and power x 0.995 apply (Table 3).

From the design altitude, corrections of capacity x 0.973 and power x 1.020 apply (Table 4).

From the design glycol strength, corrections of capacity x 1.0027 and power x 1.0009 apply (Interpolation from Table 8).

Applying these factors to the selection: YCAL0217SB

$$\text{Cooling Capacity} = 164.9 \times 0.987 \times 0.973 \times 1.0027 = 158.8 \text{ kW}$$

$$\text{Compressor Power} = 59.7 \times 0.995 \times 1.02 \times 1.0009 = 60.6 \text{ kW}$$

For the glycol concentration specified and a leaving liquid temperature of - 2°C, the Glycol Factor is 0.2457 from table 6. The flow rate can be determined, therefore, from the formula shown in "Data Required".

$$158.8 \text{ kW} = \frac{(2 - (-2)) \times \text{Flow (l/s)}}{0.2457}$$

$$\text{Flow rate} = \frac{158.8 \times 0.2457}{4} = 9.75 \text{ (l/s)}$$

This satisfies the Operating Limits.

Cooler pressure drop = 14.5 kPa (Figure 3) x 1.191 (correction factor, Table 9 for 29% strength).

Cooler pressure drop = 17.3 kPa.

GLYCOL FACTORS TABLE 6

LCLT °C	% by Weight				
	10	20	30	40	50
	Ethylene Glycol Factor				
10	0.2404	0.2515	0.2577	0.2734	0.2876
5	0.2399	0.2510	0.2579	0.2753	0.2906
0	0.2397	0.2505	0.2581	0.2772	0.2916
-5	0.2394	0.2501	0.2583	0.2791	0.2936
-10			0.2586	0.2800	0.2977

LCLT °C	% by Weight				
	10	20	30	40	50
	Propylene Glycol Factor				
10	0.2402	0.2444	0.2480	0.2578	0.2683
5	0.2394	0.2435	0.2476	0.2580	0.2693
0	0.2386	0.2426	0.2466	0.2572	0.2700
-5		0.2414	0.2458	0.2574	0.2700
-10			0.2447	0.2570	0.2708

RECOMMENDED CONCENTRATIONS TABLE 7

Leaving Liquid Temperature °C	Ethylene Glycol Concentration % Weight	Propylene Glycol Concentration % Weight
4	11	14
2	17	21
0	21	25
-2	24	29
-4	28	32
-6	32	36

GLYCOL CONCENTRATION FACTORS TABLE 8

% by Weight	Ethylene Glycol		Propylene Glycol	
	Capacity Factor	Power Factor	Capacity Factor	Power Factor
10	1.015	1.007	1.039	1.012
20	1.008	1.004	1.027	1.009
30	1.000	1.000	1.000	1.000
40	0.990	0.995	0.970	0.990
50	0.979	0.989	0.934	0.979

PRESSURE DROP CORRECTIONS TABLE 9

% by Weight	Pressure Drop Correction Factor	
	Ethylene Glycol	Propylene Glycol
10	1.03	1.05
20	1.06	1.11
30	1.09	1.20
40	1.13	1.29
50	1.16	1.46

TABLE 11

PHYSICAL DATA

Model			0147SB	0173SB	0197SB	0217SB	0253SB
Refrigerant circuits			2	2	2	2	2
Refrigerant Charge	Circuit 1 ⁽¹⁾	kg	23.5	27	35	35	40
	Circuit 2 ⁽¹⁾	kg	23.5	27	27	35	40
Oil Charge	Circuit 1	l	8	13.2	12	12	19.8
	Circuit 2	l	8	13.2	11.4	12	19.8
Compressor	Number		4	4	6	6	6
	Qty./Type (circuit 1)		2 / Scroll	2 / Scroll	3 / Scroll	3 / Scroll	3 / Scroll
	Qty./Type (circuit 2)		2 / Scroll	2 / Scroll	3 / Scroll	3 / Scroll	3 / Scroll
Unit Capacity Control		%	25 to 100	25 to 100	16 to 100	16 to 100	16 to 100
Evaporator	Number		1	1	1	1	1
	Water volume per evaporator	l	95	95	143	143	130
Air Cooled	Total coil face area	m ²	12	12	14	14	14
Condenser	Number of tube rows		2	3	2	2	3
	Number of fans (circuit 1)		2	2	2	2	2
	Number of fans (circuit 2)		2	2	2	2	2
Standard Fans	Nominal speed (950 rpm) Total airflow	m ³ /s	22.3	21.7	26.4	26	25.3
Low Sound Fans	Nominal speed (710 rpm) Total airflow	m ³ /s	21.8	21.2	25.8	25.4	24.7
Dual Speed Fans	High Speed (660 rpm) Total airflow	m ³ /s	20.9	20.4	24.8	24.4	23.7
	Low Speed (520 rpm) Total airflow	m ³ /s	15.9	15.5	18.8	18.5	18
High Head Fans	Nominal speed (1410 rpm) Total airflow	m ³ /s	32.6	32.6			
	Nominal speed (950 rpm) Total airflow	m ³ /s			32.6	32.6	32.6
Weight (aluminum fins)	Operating	kg	1933	2180	2573	2648	2802
	Shipping	kg	1824	2071	2440	2515	2662
Additional weight for copper fin coils		kg	174	261	203	232	304
Sound level ⁽²⁾ to EN 292 1991	Standard unit (950 rpm)	dBA	76	76	77	77	77
	Low sound fans (710 rpm)	dBA	73	73	74	74	74
	Low sound fans (710 rpm) & blankets	dBA	72	72	73	73	73
	Dual speed fans (660 rpm)	dBA	73	73	74	74	74
	Dual speed fans (520 rpm)	dBA	71	71	72	72	72
	Dual speed fans (660 rpm) & blankets	dBA	72	72	73	73	73
	Dual speed fans (520 rpm) & blankets	dBA	70	70	71	71	71
Dimensions	Length	mm	3022	3022	3022	3022	3022
	Width	mm	2045	2045	2311	2311	2311
	Height	mm	2282	2282	2473	2473	2473

Model			0287SB	0317SB	0347SB	0377SB
Refrigerant circuits			2	2	2	2
Refrigerant Charge	Circuit 1 ⁽¹⁾	kg	48	48	60	60
	Circuit 2 ⁽¹⁾	kg	40	48	54	60
Oil Charge	Circuit 1	l	13.2	13.2	17.7	17.7
	Circuit 2	l	8.8	13.2	13.2	17.7
Compressor	Number		5	6	6	6
	Qty./Type (circuit 1)		3 / Scroll	3 / Scroll	3 / Scroll	3 / Scroll
	Qty./Type (circuit 2)		2 / Scroll	3 / Scroll	3 / Scroll	3 / Scroll
Unit Capacity Control		%	20 to 100	16 to 100	16 to 100	16 to 100
Evaporator	Number		1	1	1	1
	Water volume per evaporator	l	113.5	113.5	221.7	221.7
Air Cooled	Total coil face area	m ²	15.6	15.6	17.8	17.8
Condenser	Number of tube rows		3	3	3	3
	Number of fans (circuit 1)		3	3	3	3
	Number of fans (circuit 2)		3	3	3	3
Standard Fans	Nominal speed (950 rpm) Total airflow	m ³ /s	37.1	37.1	37.6	37.6
Low Sound Fans	Nominal speed (710 rpm) Total airflow	m ³ /s	36.3	36.3	37.2	37.2
Dual Speed Fans	High Speed (660 rpm) Total airflow	m ³ /s	34.8	34.8	35.7	35.7
	Low Speed (520 rpm) Total airflow	m ³ /s	26.5	26.5	27.2	27.2
High Head Fans	Nominal speed (1410 rpm) Total airflow	m ³ /s				
	Nominal speed (950 rpm) Total airflow	m ³ /s	49.0	49.0	49.0	49.0
Weight (aluminum fins)	Operating	kg	3215	3273	3848	3964
	Shipping	kg	3101	3159	3626	3742
Additional weight for copper fin coils		kg	377	377	428	428
Sound level ⁽²⁾ to EN 292 1991	Standard unit (950 rpm)	dBA	78	78	78	78
	Low sound fans (710 rpm)	dBA	75	75	75	75
	Low sound fans (710 rpm) & blankets	dBA	74	74	74	74
	Dual speed fans (660 rpm)	dBA	75	75	75	75
	Dual speed fans (520 rpm)	dBA	72	72	72	72
	Dual speed fans (660 rpm) & blankets	dBA	74	74	74	74
	Dual speed fans (520 rpm) & blankets	dBA	71	71	71	71
Dimensions	Length	mm	3824	3824	4281	4281
	Width	mm	2240	2240	2240	2240
	Height	mm	2439	2439	2439	2439

(1) Liquid sub-cooling measured at the liquid line should be between 8.5 and 11.0 °C at circuit full load. Sub-cooling is determined by the level of refrigerant charge in each system.

(2) Sound Pressure levels are 1 m from the Control Panel, at a height of 1.6 m from the unit base. Levels may vary at different positions around the unit.

DIMENSIONS (continued)

YCAL0197SB, 0217SB and 0253SB

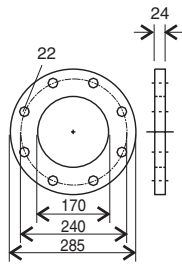

VIEW B

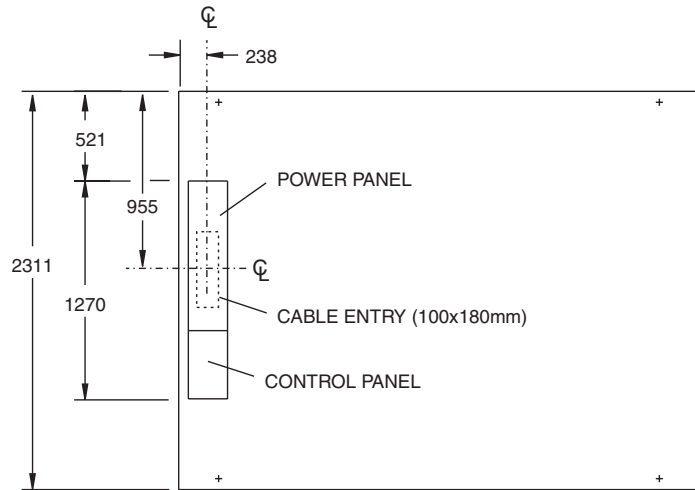

TOP VIEW

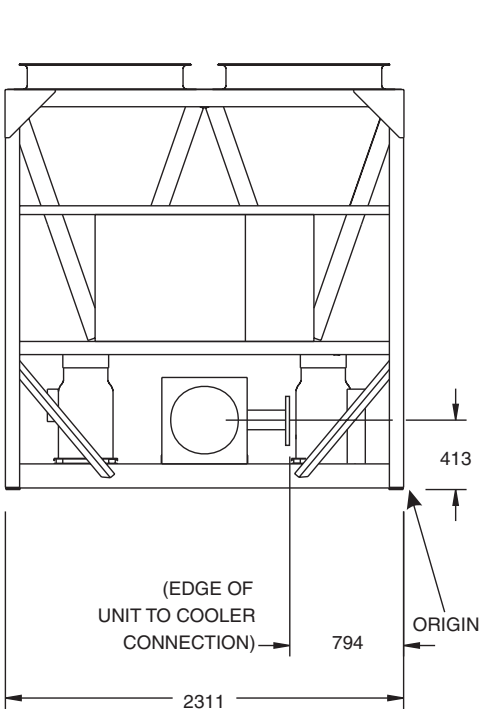

VIEW A-A

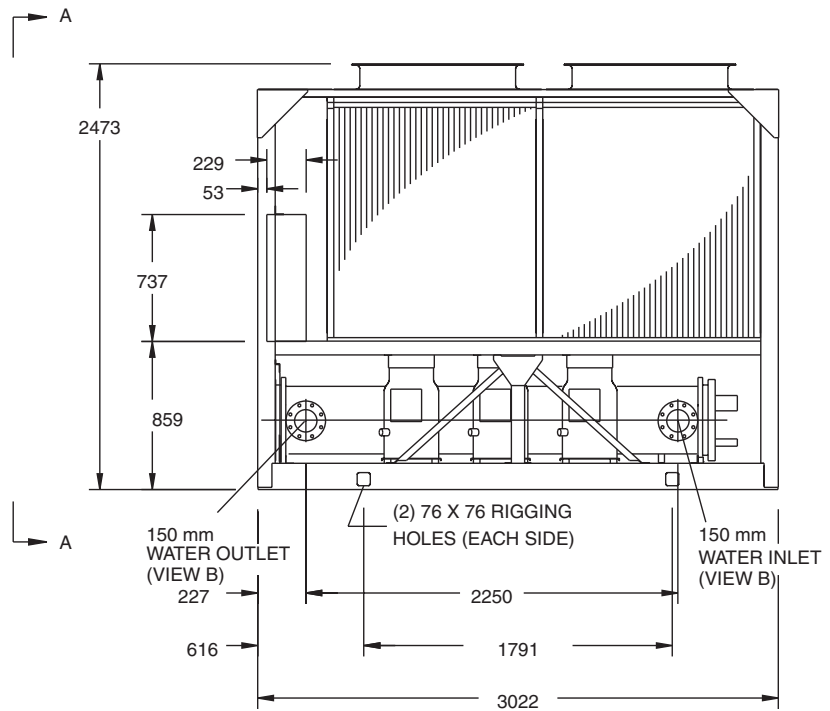

SIDE VIEW

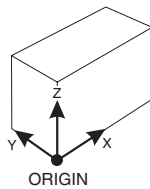

Model	Centre of Gravity from origin (mm)		
	X	Y	Z
0197SB	1430	1167	764
0217SB	1430	1159	764
0253SB	1437	1159	782